



YBFC Fan Coil Units



The power behind **your mission**



Product Introduction

YBFC Fan Coil Units

YBFC high-efficiency fan-coil units are divided into two major series - ceiling concealed installation and vertical concealed installation. Each range has 2 or 3 pipes for selection, each with 10 models. Under standard working conditions the airflow ranges from 180m³/h to 2380m³/h (high speed), the cooling capacity ranges from 1.78 to 12.94kW, and the heating capacity ranges from 1.63 to 21.74kW. There is a wide range of products, so the different needs of customers can be met. The products are rigorous in design and meticulous in manufacturing; novel in style and advanced in structure; they have high performance, low noise, low power consumption, and high safety and reliability, and they offer easy maintenance and installation.

Design Features

High Efficiency

The heat exchanger units adopt high-quality copper tubes, and are equipped with high-efficiency corrugated louver hydrophilic aluminum fins, using advanced mechanical non-expansion tube technology with high heat exchange efficiency. Equipped with large air flow and low noise fans to enhance heat transfer, so heat transfer efficiency is maximized.

Quiet Operation

All units are optimized for maximum performance. Each fan has been thoroughly checked to ensure high efficient and quiet operation.

No Condensation

The drain pan of the unit is integrally stamped and formed, so there are no welding seams or solder joints; flame-retardant insulating material is integrally attached to the pan to prevent dripping, leakage and condensation.

Easy Installation

The vertical concealed fan-coil unit can be reliably wall-mounted under window sills, and customers can decorate their rooms to be comfortable and beautiful according to their own preferences.

Easy Maintenance

The motor uses imported high-precision and high-quality ball bearings, so there is no need to supplement with oil; it is self-lubricating, with low noise and a long lifespan. The central shafts of the motor have been tempered and the surfaces have been given an anti-corrosion treatment, making them very durable.

Nomenclature

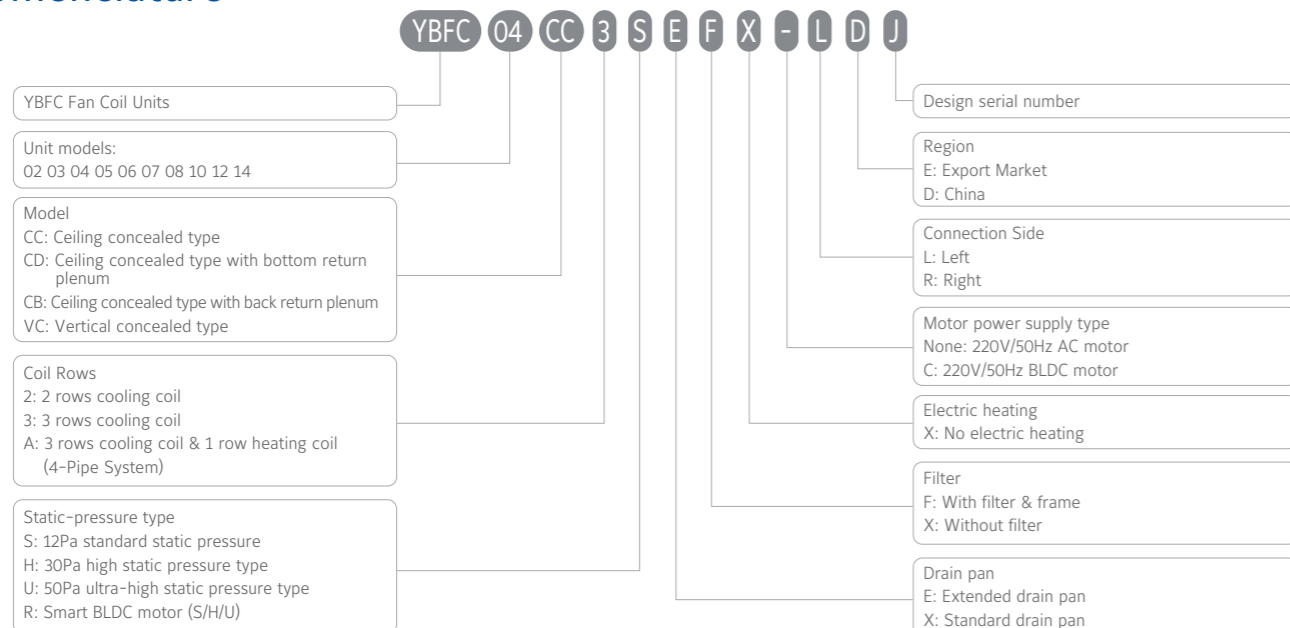

Flexible Application

Provides a variety of options to meet the different needs of customers.

Quality Assurance

YBFC fan coils have passed the United States Air Conditioning Refrigeration Association AHRI Certification.



Thermostats

APC-TMS 2000 thermostat
Working modes: cooling/heating/ventilation



T8000 thermostats
Working modes: cooling/heating/ventilation



YBFC Technical Specifications | 2-Pipe | 2 Rows

Model		YBFC02	YBFC03	YBFC04	YBFC05	YBFC06	YBFC07	YBFC08	
Rated Air Flow m³/h (Static Pressure S/H/U)	High	360	520	690	870	1030	1190	1360	
	Medium	270/270/270	410/440/390	520/535/530	660/660/700	750/790/800	860/910/850	1030/1135/1200	
	Low	190/180/190	270/310/270	350/370/360	440/440/530	500/540/580	700/620/590	640/810/860	
Rated Cooling Capacity kW (Static Pressure S/H/U)	Total Heat	High	2.0/2.0/2.0	3.03/3.03/3.03	3.6/3.6/3.6	4.5/4.5/4.5	5.4/5.4/5.4	6.3/6.3/6.3	7.2/7.2/7.2
	Sensible Heat	High	1.42/1.43/1.35	2.1/2.1/2.1	2.71/2.65/2.71	3.19/3.36/3.34	3.89/3.89/3.86	4.44/4.44/4.44	5.41/5.41/5.3
Rated Heating Capacity kW (Static Pressure S/H/U)	High	3.16/3.19/3.06	5.05/5.05/5.05	6.09/5.97/6.09	7.11/7.33/7.29	8.74/8.74/8.56	10.07/10.07/10.07	12.49/12.49/12.28	
Input Power W (Static Pressure S/H/U)	AC Motor	High	32/38/41	42/54/58	57/68/76	72/80/92	90/99/114	107/120/130	127/142/165
		Medium	24/30/36	30/45/47	51/59/67	56/73/84	82/87/112	99/99/110	109/138/161
		Low	18/23/24	25/34/40	42/50/56	42/61/76	62/70/110	78/82/91	91/117/154
	Smart BLDC Motor	High	15/19/25	22/28/36	27/34/45	39/47/60	52/62/76	60/72/87	61/75/93
		Medium	11/12/15	11/17/19	18/17/21	20/25/29	23/30/35	23/33/40	37/43/54
		Low	7/8/10	6/9/10	9/9/12	11/13/14	12/16/16	13/15/18	21/23/29
Running Current A (Static Pressure S/H/U)	AC Motor	High	0.15/0.18/0.19	0.20/0.26/0.28	0.27/0.32/0.36	0.33/0.38/0.44	0.43/0.47/0.51	0.51/0.58/0.62	0.61/0.66/0.74
	Smart BLDC Motor	High	0.17/0.20/0.24	0.21/0.26/0.32	0.26/0.33/0.40	0.38/0.41/0.51	0.45/0.53/0.65	0.49/0.60/0.71	0.66/0.81/0.99
Number Of Motors		1	1	1	1	1	1	2	
Sound Level dB(A) (Static Pressure S/H/U)	AC Motor	High	34/33/36	35/34.5/38	36/38/41	40/39.5/41.5	44/40/42.5	45.5/42/43.5	45.5/42/44
	Smart BLDC Motor	High	34/33/36	35/34.5/38	36/38/41	40/39.5/41.5	44/40/42.5	45.5/42/43.5	45.5/42/44
Water Flow l/s (Static Pressure S/H/U)	Cooling Conditions	High	0.096/0.096/0.096	0.145/0.145/0.145	0.172/0.172/0.172	0.215/0.215/0.215	0.258/0.258/0.258	0.301/0.301/0.301	0.344/0.344/0.344
	Heating Conditions	High	0.096/0.096/0.096	0.145/0.145/0.145	0.172/0.172/0.172	0.215/0.215/0.215	0.258/0.258/0.258	0.301/0.301/0.301	0.344/0.344/0.344
Water Pressure Drop kPa (Static Pressure S/H/U)	Cooling Conditions	High	30.0	28.0	30.0	27.0	38.0	40.0	40.0
	Heating Conditions	High	30.0	28.0	30.0	27.0	38.0	40.0	40.0
Net Weight Of Unit kg	CC	8.7	10.4	11.8	12.3	13.6	15.3	19.2	
	CB/CD	11.8	14	15.8	16.5	18.1	20.4	25.1	
Coil	Fin Type	Corrugated-Louver Aluminum Fin With Hydrophilic Coating							
	Working Pressure	1.6MPa							
Fan	Type	Forward Curved Centrifugal Fan							
	Type	Single Phase Permanent Split-Capacitor (PSC) Motor Or Brushless DC (BLDC) Motor							
Motor	Protection Class	IP20							
	Insulation Class	B							
Water Inlet And Outlet Connections	Pipe Size	Rc 3/4"							
Drain Pan Connection	Pipe Size	R2 3/4"							

Note:

- Rated cooling conditions: air inlet at 27°C DB/19.5°C WB, chilled water inlet/outlet at 7°C/12°C.
- Rated heating conditions: air inlet at 21°C DB, hot water inlet at 60°C.
- The air flow, cooling total/sensible heat, and heating capacity are based on the CC type units. Refer to the selection software for the performance report of VC units.
- Sound level: S-type (12Pa) with 1m air duct on the return side and test point is 1 meter below the units (GB/T19232-2019 Figure C.2).
H/U type (30/50Pa) with 2m air duct on both supply and return side and test point is 1m directly below the units. (GB/T19232-2019 Figure C.3).
- Left or right sidedness cannot be adjusted on site.
- Static pressure type: S standard type (12Pa), H high static pressure type (30Pa), U ultra high static pressure type (50Pa)
- The BLDC motor unit is only applicable to CC/CB/CD units.
- The weight of the unit in the table is the weight of the AC motor unit, and the weight for the BLDC motor unit includes an additional 3.5 kg to the data in the above table.
- The above air flow, cooling capacity, heating capacity, input power and running current are based on 220V input voltage. When a unit is used with 230V input voltage, the performance data should be estimated and adjusted with below correction factors.
 - Airflow: 1.04.
 - Cooling capacity and heating capacity: 1.02.
 - Input power: 1.07.
 - Running current: 1.03.
 - Sound Level (Noise): +1.5dB.

YBFC Technical Specifications | 2-Pipe | 3 Rows

Model		YBFC02	YBFC03	YBFC04	YBFC05	YBFC06	YBFC07	YBFC08	YBFC10	YBFC12	YBFC14	
Rated Air Flow m ³ /h (Static Pressure S/H/U)	High	340	520	680	850	1020	1190	1360	1710	2040	2380	
	Medium	270/270/270	390/430/380	520/520/530	640/640/680	730/770/780	850/910/840	1000/1120/1150	1290/1290/1320	1530/1530/1620	1790/1790/1800	
	Low	170/170/190	260/300/270	340/360/360	430/430/500	485/530/540	590/600/580	640/780/840	860/860/900	1020/1020/1130	1190/1190/1320	
Rated Cooling Capacity kW (Static Pressure S/H/U)	Total Heat	High	2.43/2.45/2.5	3.4/3.45/3.4	4.22/4.22/4.22	5.2/5.16/5.2	6.4/6.4/6.3	6.68/6.68/6.68	8.6/8.5/8.15	9.1/9.1/9.07	11.45/11.3/11.3	13.6/13.5/13.05
	Sensible Heat	High	1.58/1.59/1.6	2.29/2.32/2.29	3.08/3.08/3.08	3.59/3.5/3.59	4.47/4.47/4.44	4.82/4.82/4.82	6.03/5.96/5.9	7/6.8/6.8	8.34/8.23/8.23	9.9/9.9/9.86
Rated Heating Capacity kW (Static Pressure S/H/U)	High	3.77/3.8/3.85	5.38/5.46/5.38	6.98/6.98/6.98	8.17/8.18/8.17	10.13/10.13/10.05	10.83/10.83/10.83	13.33/13.18/12.9	16.16/15.96/15.91	18.41/18.38/18.38	22.16/22.1/21.82	
Input Power W (Static Pressure S/H/U)	AC Motor	High	30/37/40	42/54/57	56/64/74	69/78/85	88/97/105	107/119/129	125/137/153	147/161/180	178/197/224	207/241/277
		Medium	21/30/35	31/46/49	49/54/67	58/68/77	72/88/105	96/109/112	108/129/151	119/149/179	141/166/219	171/225/242
		Low	17/23/33	25/38/42	40/46/55	43/56/70	55/72/95	74/91/92	89/106/141	98/130/168	114/139/203	141/190/225
	Smart BLDC Motor	High	14/18/24	20/26/34	25/33/43	37/45/58	50/62/78	56/70/85	58/72/90	78/99/125	102/125/155	134/161/192
		Medium	11/12/14	11/17/19	17/17/21	20/25/29	23/30/37	23/33/40	36/43/54	43/46/56	48/61/75	54/80/87
		Low	6/7/10	6/9/10	9/10/12	11/13/14	12/16/17	13/16/18	21/23/29	23/24/28	23/28/35	30/34/41
Running Current A (Static Pressure S/H/U)	AC Motor	High	0.15/0.18/0.19	0.20/0.26/0.27	0.27/0.31/0.35	0.33/0.37/0.41	0.42/0.46/0.50	0.51/0.57/0.62	0.60/0.66/0.73	0.72/0.77/0.86	0.85/0.94/1.07	0.99/1.15/1.33
	Smart BLDC Motor	High	0.16/0.19/0.23	0.20/0.25/0.31	0.25/0.32/0.39	0.37/0.40/0.50	0.44/0.52/0.64	0.48/0.59/0.70	0.64/0.79/0.97	0.74/0.90/1.11	0.95/1.14/1.40	1.38/1.58/1.69
Number Of Motors		1	1	1	1	1	1	2	2	2	2	
Sound Level dB(A) (Static Pressure S/H/U)	AC Motor	High	33/32/36	34/34.5/38.5	36.5/38/41	40/38.5/41.5	41/40/42.5	45/41/43.5	44.5/40.5/44	47/43/45	48/44/47	50.5/46/46.5
	Smart BLDC Motor	High	33/31.5/35.5	34/34.5/38	36.5/38/41.5	40/38/40	41/40/42	45/41/43.5	44.5/40.5/43	47/43/45	48/44/46.5	50/45.5/46
Water Flow l/s (Static Pressure S/H/U)	Cooling Conditions	High	0.116/0.117/0.120	0.163/0.165/0.163	0.202/0.202/0.202	0.249/0.247/0.249	0.306/0.306/0.301	0.32/0.32/0.32	0.411/0.407/0.39	0.435/0.435/0.434	0.548/0.541/0.541	0.651/0.646/0.624
	Heating Conditions	High	0.116/0.117/0.120	0.163/0.165/0.163	0.202/0.202/0.202	0.249/0.247/0.249	0.306/0.306/0.301	0.32/0.32/0.32	0.411/0.407/0.39	0.435/0.435/0.434	0.548/0.541/0.541	0.651/0.646/0.624
Water Pressure Drop kPa (Static Pressure S/H/U)	Cooling Conditions	High	25.0	26.0	20.0	28.0	40.0	30.0	38.0	38.0	40.0	50.0
	Heating Conditions	High	25.0	26.0	20.0	28.0	40.0	30.0	38.0	38.0	40.0	50.0
Net Weight Of Unit kg	CC	9.1	10.9	12.2	13	14.4	16.1	20.2	22.5	24	26.7	
	CB/CD	12.2	14.5	16.1	17.2	18.8	21.2	26.1	28.5	31.1	34.7	
	VC	22.7	24.6	27.6	29.3	32	42.0	44.2	46.3	52.5	63.0	
Coil	Fin Type	Corrugated-Louver Aluminum Fin With Hydrophilic Coating										
	Working Pressure	1.6MPa										
Fan	Type	Forward Curved Centrifugal Fan										
Motor	Type	Single Phase Permanent Split-Capacitor (PSC) Motor Or Brushless DC (BLDC) Motor										
	Protection Class	IP20										
	Insulation Class	B										
Water Inlet And Outlet Connections	Pipe Size	Rc 3/4"										
Drain Pan Connection	Pipe Size	R2 3/4"										

- Note:
- Rated cooling conditions: air inlet at 27°C DB/19.5°C WB, chilled water inlet/outlet at 7°C/12°C.
 - Rated heating conditions: air inlet at 21°C DB, hot water inlet at 60°C.
 - The air flow, cooling total/sensible heat, and heating capacity are based on CC type units. Refer to the selection software for the performance report of VC units.
 - Sound level: S-type (12Pa) with 1m air duct on the return side and test point is 1 meter below the units (GB/T19232-2019 Figure C.2).
H/U type (30/50Pa) with 2m air duct on both supply and return sides and test point is 1m directly below the units. (GB/T19232-2019 Figure C.3).
 - Left or right sidedness cannot be adjusted on site.
 - Static pressure type: S standard type (12Pa), H high static pressure type (30Pa), U ultra high static pressure type (50Pa)
 - The BLDC motor unit is only applicable to CC/CB/CD units.
 - The weight of the unit in the table is the weight of the AC motor unit, and the weight for the BLDC motor unit includes an additional 3.5 kg to the data in the above table.
 - The above air flow, cooling capacity, heating capacity, input power and running current are based on 220V input voltage. When a unit is used with 230V input voltage, the performance data should be estimated and adjusted with below correction factors.
 - Airflow: 1.04.
 - Cooling capacity and heating capacity: 1.02.
 - Input power: 1.07.
 - Running current: 1.03.
 - Sound Level (Noise): +1.5dB.

YBFC Technical Specifications | 4-Pipe | 3+1 Rows

Model		YBFC02	YBFC03	YBFC04	YBFC05	YBFC06	YBFC07	YBFC08	YBFC10	YBFC12	YBFC14	
Rated Air Flow m ³ /h (Static Pressure S/H/U)	High	340	510	680	850	1020	1190	1360	1700	2040	2380	
	Medium	270/270/270	350/420/380	480/520/520	620/620/640	720/760/760	840/900/830	990/1080/1100	1270/1270/1300	1500/1500/1550	1750/1750/1750	
	Low	170/170/180	240/300/260	310/352/350	420/420/480	480/520/520	560/590/580	640/780/820	850/850/880	1000/1000/1100	1160/1160/1280	
Rated Cooling Capacity kW (Static Pressure S/H/U)	Total Heat	High	2.34/2.34/2.2	3.3/3.21/3.21	4.2/4.15/4.15	5.04/5.1/4.9	6.18/5.77/5.9	6.6/6.6/6.6	8.4/8.12/8	9.11/9/9	10.8/11.15/10.8	12.8/12.6/12.6
	Sensible Heat	High	1.48/1.48/1.39	2.23/2.17/2.17	2.94/2.9/2.9	3.5/3.55/3.41	4.36/4.1/4.2	4.8/4.8/4.8	5.94/5.84/5.77	6.86/6.71/6.59	8.06/8.05/7.86	9.6/9.44/9.44
Rated Heating Capacity kW (Static Pressure S/H/U)	High	1.78/1.78/1.68	2.59/2.52/2.52	3.18/3.14/3.14	3.82/3.82/3.67	4.79/4.79/4.58	5.25/2.52	6.47/6.47/6.16	6.95/6.79/6.67	8.27/8.26/8.06	9.72/9.66/9.66	
Input Power W (Static Pressure S/H/U)	AC Motor	High	30/37/40	41/53/56	56/64/72	68/76/85	88/96/107	105/117/125	123/133/149	146/155/190	172/192/218	206/236/275
		Medium	21/31/38	32/48/48	50/58/66	57/73/76	74/93/105	94/100/108	105/129/152	122/151/185	137/166/212	169/218/238
		Low	17/24/35	28/40/41	40/49/54	44/62/68	58/80/95	73/81/89	87/109/137	103/130/173	112/143/194	139/185/214
	Smart BLDC Motor	High	14/18/24	20/26/34	25/33/43	37/45/58	50/62/78	56/70/85	58/72/90	78/99/125	102/125/155	134/161/192
		Medium	11/12/14	11/17/19	17/17/21	20/25/29	23/30/37	23/33/40	36/43/54	43/46/56	48/61/75	54/80/87
		Low	6/7/10	6/9/10	9/10/12	11/13/14	12/16/17	13/16/18	21/23/29	23/24/28	23/28/35	30/34/41
Running Current A (Static Pressure S/H/U)	AC Motor	High	0.15/0.18/0.19	0.2/0.25/0.27	0.27/0.31/0.34	0.33/0.36/0.41	0.42/0.46/0.51	0.5/0.56/0.6	0.59/0.64/0.71	0.70/0.74/0.91	0.82/0.92/1.04	0.98/1.13/1.32
	Smart BLDC Motor	High	0.16/0.19/0.23	0.20/0.25/0.31	0.25/0.32/0.39	0.37/0.40/0.50	0.44/0.52/0.64	0.48/0.59/0.70	0.64/0.79/0.97	0.74/0.90/1.11	0.95/1.14/1.40	1.38/1.58/1.69
Number Of Motors		1	1	1	1	1	1	2	2	2	2	
Sound Level dB(A) (Static Pressure S/H/U)	AC Motor	High	34/33/36	35/35.5/38	36.5/39.5/41	40.5/39.5/41.5	44/41/42.5	45.5/42/43.5	45/41/44	48/43.5/46	49.5/44/46.5	50.5/47/47
	Smart BLDC Motor	High	33/31.5/35.5	34/34.5/38	36.5/38/40.5	40/38/40	44/40/42	45/41/43.5	44.5/40.5/43	47/43/45	48/44/46.5	50/45.5/46
Water Flow l/s (Static Pressure S/H/U)	Cooling Conditions	High	0.112/0.112/0.105	0.158/0.154/0.154	0.201/0.199/0.199	0.241/0.244/0.234	0.296/0.276/0.282	0.316/0.316/0.316	0.402/0.389/0.383	0.436/0.431/0.431	0.517/0.533/0.517	0.612/0.603/0.603
	Heating Conditions	High	0.043/0.043/0.04	0.062/0.06/0.06	0.076/0.075/0.075	0.091/0.091/0.088	0.115/0.115/0.11	0.124/0.124/0.124	0.155/0.155/0.147	0.166/0.162/0.16	0.198/0.198/0.193	0.233/0.231/0.231
Water Pressure Drop kPa (Static Pressure S/H/U)	Cooling Conditions	High	24.0	25.0	30.0	27.0	33.0	30.0	37.0	36.0	38.0	48.0
	Heating Conditions	High	20.0	30.0	19.5	27.5	30.0	40.0	38.0	40.0	50.0	
Net Weight Of Unit kg	CC	9.6	11.6	12.8	14	15.3	17.1	21.2	23.5	25	28.1	
	CB/CD	12.7	15.2	16.8	18.2	19.8	22.2	27.1	29.5	32	36.1	
	VC	22.7	24.6	27.6	29.3	32	42.0	44.2	46.3	52.5	63.0	
Coil	Fin Type	Corrugated-Louver Aluminum Fin With Hydrophilic Coating										
	Working Pressure	1.6MPa										
Fan	Type	Forward Curved Centrifugal Fan										
Motor	Type	Single Phase Permanent Split-Capacitor (PSC) Motor Or Brushless DC (BLDC) Motor										
	Protection Class	IP20										
	Insulation Class	B										
Water Inlet And Outlet Connections	Pipe Size	Rc 3/4"										
Drain Pan Connection	Pipe Size	R2 3/4"										
Hot Water Inlet And Outlet Connections	Pipe Size	Rc 1/2"										

- Note:
- Rated cooling conditions: air inlet at 27°C DB/19.5°C WB, chilled water inlet/outlet at 7°C/12°C.
 - Rated heating conditions: air inlet at 21°C DB, hot water inlet at 60°C.
 - The air flow, cooling total/sensible heat, and heating capacity are based on CC type units. Refer to the selection software for the performance report of VC units.
 - Sound level: S-type (12Pa) with 1m air duct on the return side and test point is 1 meter below the units (GB/T19232-2019 Figure C.2).
H/U type (30/50Pa) with 2m air duct on both supply and return sides and test point is 1m directly below the units. (GB/T19232-2019 Figure C.3).
 - Left or right sidedness cannot be adjusted on site.
 - Static pressure type: S standard type (12Pa), H high static pressure type (30Pa), U ultra high static pressure type (50Pa)
 - The BLDC motor unit is only applicable to CC/CB/CD units.
 - The weight of the unit in the table is the weight of the AC motor unit, and the weight for the BLDC motor unit includes an additional 3.5 kg to the data in the above table.
 - The above air flow, cooling capacity, heating capacity, input power and running current are based on 220V input voltage. When a unit is used with 230V input voltage, the performance data should be estimated and adjusted with below correction factors.
 - Airflow: 1.04.
 - Cooling capacity and heating capacity: 1.02.
 - Input power: 1.07.
 - Running current: 1.03.
 - Sound Level (Noise): +1.5dB.

YBFC Optional Accessories – BLDC Brushless DC Motor

As an energy-saving, environmentally friendly, quiet and comfortable product, the brushless DC (BLDC) fan coil unit can be widely used in public places such as villas, apartments, high-end hotels, hospitals, office buildings, etc.



Energy Efficient

- ‡ The efficiency is doubled compared to the traditional AC motor, and the average power consumption is only 50% to 70% of that of the AC motor.



Smart BLDC:

In automatic operation mode, the unit automatically performs stepless adjustment of fan speed, optimizing energy consumption. In manual mode, the user can set the fan speed at high, medium, or low according to different indoor load requirements.

Low Noise

Smart BLDC:

- ‡ Uses sine wave PWM control, so the motor runs smoothly, and vibration and noise are reduced. Noise is 1 to 2dB(A) lower than an AC motor.
- ‡ Supports lower speed operation at a part load, resulting in lower noise.



Smart Control

Smart BLDC:

- ‡ Users can control single unit or multiple units centrally. A single wired controller can control up to 8 units of the same model at the same time.
- ‡ The units come with an RS485 communication interface, supporting standard Modbus communication protocols, and can be linked with building automation systems to bring about centralized operations and management of remote automation and monitoring.
- ‡ The optional dedicated thermostat, touch LCD screen or simplified LCD screen are beautiful and elegant, and a wide variety of colors are available, allowing seamless integration with existing decorations.



Touch screen BLDC dedicated thermostat



Simplified BLDC dedicated thermostat

- ‡ Easy operation, with automatic and manual modes. Includes timer, fault alarm, parameter setting, and other functions.

Comfort And Safety

Smart BLDC:

- ‡ Stepless airflow adjustment allow for precise room temperature control, improving occupant comfort.
- ‡ The units come with a step-up module to ensure the safety and stability of the unit, so they can be applied in a wider voltage range, and external voltage fluctuations that cause the unit to degrade or damage the unit can be avoided.
- ‡ Two-level overcurrent and overheat protection to prevent overloading and burning the motor.



Flexible Design

- ‡ The maximum or minimum speed of the fan can be adjusted to maintain the indoor air flow requirements.

Smart BLDC Unit:

- ‡ Users can adjust dipswitch to choose among 12Pa/30Pa/50Pa static pressure, depending on the required application.
- ‡ Optional TiO₂, electric heater and valve packages (on/off type or modulating).

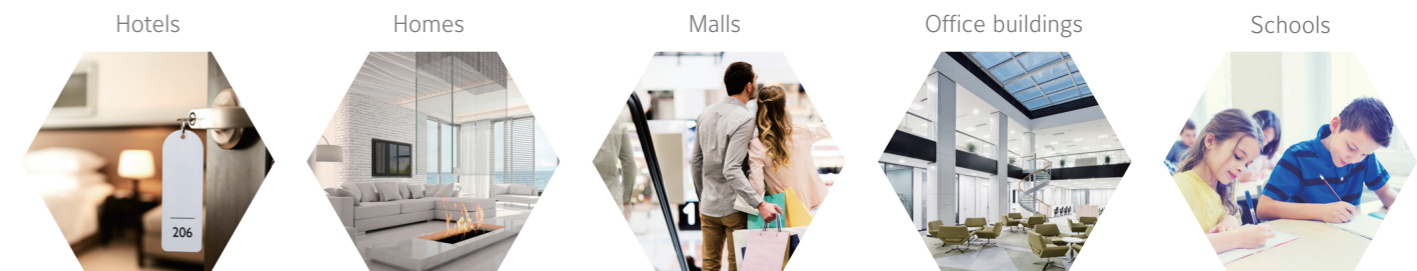

Electrical Wiring Diagrams

Circuit Diagrams

Smart BLDC Motor Unit Wiring Diagram

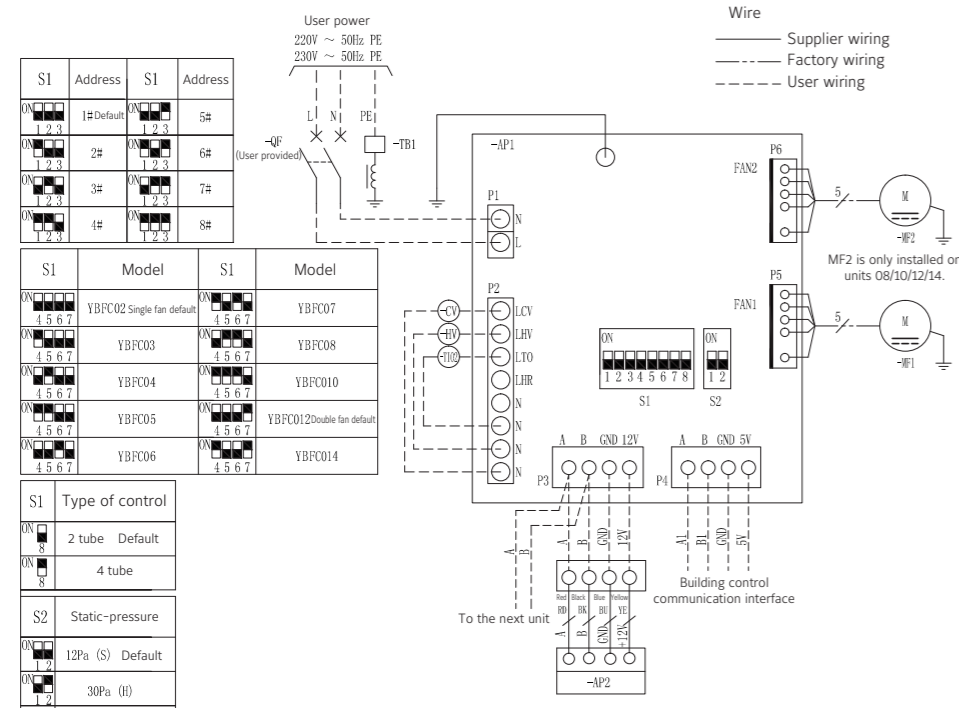

Code	Description
QF	Circuit Breaker
TB1	Ground Terminal
AP1	Control Board
CV	Cooling Valve
HV	Heating Valve
TiO ₂	Sterilizer
MF1, MF2	Fan Motor
AP2	Wired Controller

AC Motor Unit Wiring Diagram

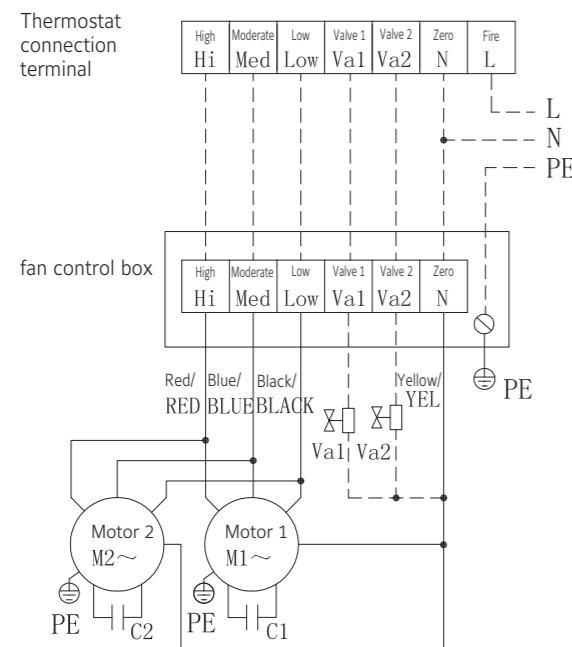

- Notes:
- Dotted lines show on-site user wiring.
 - Va1 is the chilled water valve, Va2 is the hot water valve. The two-pipe unit has no hot water valve.
 - YBFC02-07 has one motor, and YBFC08-14 has two motors.
 - All electric connections should comply with local electric installation codes.

Optional Accessories – TiO₂ Healthy Air Sterilizer

Industrial Leading Technology - Nano-TiO₂ Healthy Air Sterilizer (Optional)

Nano-scale TiO₂ healthy air sterilization and purification technology can oxidize and decompose harmful substances in the air, effectively kill bacteria and germs spread in the air, efficiently remove odors, harmful microorganisms and all other harmful substances:

- Biological contaminants - bacteria, germs...
- Organic pollutants - volatile organic compounds (VOCs), formaldehyde, benzene, etc...
- Mold, fungi, etc...
- Inorganic gaseous pollutants - NOx, SOx...
- Smoke and unpleasant odors

As optional accessories, the healthy air sterilization and purification equipment is suitable for fan coils, residential and commercial central air conditioners, and residential split units. For air-conditioning systems that have already been installed, whether they are newly fitted or renovated, we can provide suitable solution packages.

Duct Style TiO₂ Healthy Air Sterilizer

Model	Number Of Sterilizers	Input Power (W)	Weight (kg)	Dimensions (Single) Length * Height * Depth (mm)
YBFC02-06	1	22	2.59	430*190*100
YBFC07-14	2	22*2	2.59*2	430*190*100

Package TiO₂ Healthy Air Sterilizer

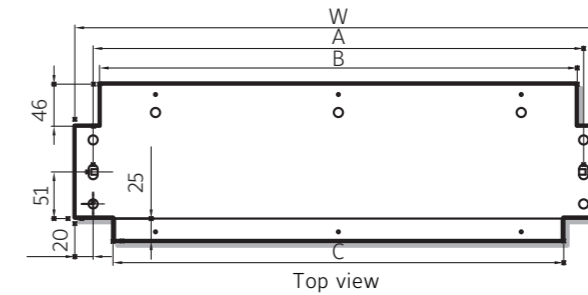

Model	Input Power (W)	Weight (kg)	Exterior Dimensions Height * Depth (mm)	W	A	B	C
YBFC02	36	4.5	268*172	514	474	460	428
YBFC03	54	5.6	268*172	664	624	640	578
YBFC04	54	6.1	268*172	744	704	690	658
YBFC05	54	6.6	268*172	804	764	750	718
YBFC06	72	7.3	268*172	904	864	850	818
YBFC07	90	8.6	268*172	1084	1044	1030	998
YBFC08	108	10.0	268*172	1284	1244	1230	1198
YBFC10	126	10.4	268*172	1334	1294	1280	1248
YBFC12	144	12.2	268*172	1584	1544	1530	1498
YBFC14	162	14.0	268*172	1834	1794	1780	1748

- The power supply of the sterilizer UV lamp is a 220V-1Ph-50Hz. To prevent injury, do not stare at the sterilizer UV lamp for a long period of time.
- The start-up of the sterilizer and the corresponding unit interlock control (the relevant wiring of the interlock control is completed by the user), when the inner fan is turned on, the sterilizer is turned on; when the inner fan is turned off, the sterilizer is turned off.



Johnson Controls:

At Johnson Controls, we transform the environments where people live, work, learn and play. From optimizing building performance to improving safety and enhancing comfort, we drive the outcomes that matter most. We deliver our promise in industries such as healthcare, education, data centers and manufacturing. With a global team of 105,000 experts in more than 150 countries and over 130 years of innovation, we are the power behind our customers' mission. Our leading portfolio of building technology and solutions includes some of the most trusted names in the industry, such as Tyco®, York®, Metasys®, Ruskin®, Titus®, Frick®, Penn®, Sabroe®, Simplex®, Ansul® and Grinnell®.

For more information, visit www.johnsoncontrols.com or follow us [@johnsoncontrols](https://twitter.com/johnsoncontrols) on Twitter.

Australia (Sydney)

Tel: +61 (2) 9805 8300
Fax: +61 (2) 9247 7750

India (Mumbai)

Tel: +91 (22) 6683 7000
Fax: +91 (22) 6683 7002

Malaysia (Kuala Lumpur)

Tel: +60 (3) 7628 4300
Fax: +60 (3) 7874 1180

China (Shanghai)

Tel: +86 (21) 2285 7000
Fax: +86 (21) 2285 7599

Indonesia (Jakarta)

Tel: +62 (21) 5366 8500
Fax: +62 (21) 5366 8300

New Zealand (Auckland)

Tel: +64 (9) 635 0880
Fax: +64 (9) 633 1862

China (Hong Kong)

Tel: +852 2885 4451
Fax: +852 2885 7760

Japan (Tokyo)

Tel: +81 (3) 5738 6100
Fax: +81 (3) 5738 6298

Singapore

Tel: +65 6748 0202
Fax: +65 6743 4420

China (Macau)

Tel: +853 2875 1820
Fax: +853 2875 1825

Korea (Seoul)

Tel: +822 1588 9117
Fax: +822 6009 9014

Thailand (Bangkok)

Tel: +66 (2) 794 0101
Fax: +66 (2) 717 1327-8

The power behind **your mission**

